

BITEC
BITUMEN TECHNOLOGY™

January 2009

MDA and MDS Mineral Design™

(APP Modified) (SBS Modified)

A Pattern-Design APP or SBS Waterproofing Membrane, Made From Select Polymers And Distilled Bitumen, Featuring Spunbond Polyester Composite Reinforcement

BITEC Mineral Design is a pattern design mineral surfaced, modified bitumen waterproofing membrane composed of carefully selected asphalts (bitumen) with superior modifying characteristics, and blended with high quality made on purpose polymers. Mineral Design is reinforced with a dimensionally stable spunbond polyester composite fabric.

Mineral Design waterproofing membrane yields the following performance characteristics:

- ★ Special Mineral Design
- ★ Impermeable to water
- ★ Low temp flexibility
- ★ UV Resistance
- ★ Excellent adhesion
- ★ Resistant to acids and most bases
- ★ Puncture resistant
- ★ Excellent workability

The spunbond polyester reinforcement used in Mineral Design, has isotropic mechanical properties giving the composite membrane similar mechanical characteristics in all directions in relation to the membrane surface. The spunbond polyester fabric gives the following properties to the Mineral Design membrane:

- ★ Dimensional stability
- ★ Flexibility
- ★ Puncture resistance

- ★ Elasticity
- ★ Mechanical strength
- ★ Fatigue resistance
- ★ Tear strength
- ★ Deterioration resistance

The mineral surface protects the membrane from ageing caused from heat and ultra violet light. Most mineral surfacings yield sufficiently high amounts of solar reflectivity to realize some energy savings, depending on building construction and use.

Mineral Design APP incorporates a smooth and even application of polyethylene film to prevent blocking of rolls and to provide a smooth, acceptable torching surface. Polyethylene film is contained on the torchable face of the roll. The polyethylene film acts as a "sight indicator" for the applicator in determining the proper flow needed to insure adequate bonding of plies and seams.

Mineral Design SBS incorporates a smooth and even application of fine sand to prevent blocking of rolls and to provide a smooth, acceptable application surface. It can be applied by using hot asphalt or by using any BITEC APPROVED ELASTOMERIC COLD PROCESS ADHESIVE. (When using cold adhesives, always follow the specific adhesive manufacturer's installation specifications.)

HANDLING AND STORAGE

Successful application and a good finished appearance depend on careful handling and storage of the Mineral Design Rolls. This is extremely important.

- All rolls must be stored on original factory pallets having a corrugated paper pad as a barrier to prevent marking of roll ends and possible distortion of the factory pattern. This corrugated paper pad comes as a part of factory packaging.
- Rolls must be stored on end with selvedge edge up. Rolls must never be left leaning or laying flat.
- All product must be stored away from direct sunlight and weather until shortly before use.
- Never double-stack pallets of Mineral Design.

Should pallets of Mineral Design be stored outside, at the job site, the polyethylene shrink-wrap bag should be slit vertically, on all sides, to improve circulation and reduce product stress during warmer weather.

Mineral Design and its various design patterns are produced by an exclusive manufacturing system covered by registered patents, held exclusively by BITEC, INC.

General Application: MDA (APP Modified)

Proper Application temperature is essential. The installer should produce a continuous, uninterrupted flow of bitumen from all laps, not to exceed $\frac{1}{8}$ to $\frac{1}{4}$ inch. Flow beyond this range may produce unsightly results.

For slopes greater than $\frac{3}{4}$ " in 12", blind-nailing the end laps is required to reduce the potential of membrane displacement resulting in pattern distortion. The fastener used will depend on the substrate. Typically blind nailing 6" to 9" o.c. is acceptable.

Begin torching the burn-off film surface of the membrane, using a sweeping motion, maintaining even heating. The actual torching motion should be done in an "L" configuration, preheating the previously installed membrane lap, then sweeping across the roll face while advancing the roll over the roof surface. As the roll is advanced, a bead of modified bitumen should be seen flowing from between the lap seam a distance of $\frac{1}{8}$ to $\frac{1}{4}$ " from the membrane edge. This "flow out" should be consistent and uninterrupted. Seams which are not fully bonded can be repaired by inserting a hot trowel between the affected seam and lightly torching. Upon removal of the hot trowel, pressure should be applied to the top ply, forcing the modified bitumen to flow out the desired distance.

All side and end laps should be a minimum of 4" and 6" respectively.

If the membrane is loose laid, an area of 40" each side of the end lap should be fully bonded to roof surface.

BITEC APP MEMBRANES MAY NOT BE INSTALLED IN HOT ROOFING ASPHALT, COLD PROCESS ADHESIVES OR BY MECHANICAL ATTACHMENT.

BITEC APP MEMBRANES ARE NOT RECOMMENDED FOR USE OVER COAL TAR OR PITCH ROOFS UNLESS THE EXISTING DECK IS SEPARATED FROM THE BITEC MEMBRANE BY A MIN. $\frac{1}{2}$ " THICK, MECHANICALLY ATTACHED RECOVER BOARD. BITEC DOES NOT ALLOW THE USE OF PLASTIC ROOFER'S CEMENT WITH ANY OF ITS MEMBRANES.

General Appli on: MDS (SBS Modified)

Depending on the type of roof, Mineral Design can be either fully adhered, spot or partially adhered, or loose laid. BITEC specifications applicable to this product should be consulted to determine which system should be employed. When applying the membrane, the fine sand surface should always be down facing the roof deck. Prior to application, the membrane should be unrolled completely, aligned, allowed to relax and set before the actual installation of the membrane occurs. The membrane should then be rolled up half way, leaving the other half fully extended. (This will insure that the membrane will remain aligned during the installation process.)

Mineral Design is designed to be applied by conventional methods of hot mopping, using ASTM D312 TYPE III mopping asphalt. ASTM TYPE IV should be used on slopes greater than 3" in 12". The Roofing Contractor shall not let the mopping asphalt temperature fall below 450°F, or overheat the asphalt to overcome rapid cooling. BITEC recommends that mopping asphalt EVT requirements be met when heating asphalt. Mopping of base and cap sheet plies shall be done at a rate of 25 lbs./100 ft. sq. in a solid mopping of hot asphalt. It is essential that the asphalt be applied uniformly at a distance not to exceed 4' in front of the advancing roll surface. A continuous, $\frac{1}{4}$ " bead of uninterrupted mopping asphalt shall be seen coming from the end and side laps. Seams which are not fully bonded can be repaired by inserting a hot trowel between the affected seam and lightly torching. Upon removal of the hot trowel, pressure should be applied to the top ply, forcing the modified bitumen to flow out the desired distance.

All side and end laps should be a minimum of 4 and 6 inches respectively.

If the membrane is loose laid, an area of 40" each side of the end lap should be fully bonded to the roof surface.

BITEC SBS HOT APPLIED MEMBRANES CAN BE INSTALLED IN HOT ROOFING ASPHALT OR IN BITEC APPROVED COLD PROCESS ADHESIVES.

BITEC SBS MEMBRANES ARE NOT RECOMMENDED FOR USE OVER COAL TAR OR PITCH ROOFS UNLESS THE EXISTING DECK IS SEPARATED FROM THE BITEC MEMBRANE BY A MINIMUM $\frac{1}{2}$ " THICK, MECHANICALLY ATTACHED RECOVER BOARD. BITEC DOES NOT ALLOW THE USE OF PLASTIC ROOFER'S CEMENT WITH ANY OF ITS MEMBRANES.

TOOLS REQUIRED

To apply BITEC Mineral Design, the only tools needed are: spatula or round nose roofer's trowel, a roofer's knife and straight-edge, a pair of work gloves, flat soled shoes, and for APP application: a propane torch with UL certified regulator, propane bottle, and an ABC dry chemical fire extinguisher.

Before using this product, be certain that all information concerning the installation of this product and safety guidelines pertaining thereto have been read and fully understood. The application of some modified membranes requires the use of explosive gas and molten asphalts, which if mishandled can and will cause personal injury and/or property damage.

THE CONTRACTOR

It is the contractor's responsibility to observe all fire prevention policies and practices, to train, instruct and warn employees on the use of torching equipment. Follow OSHA and NRCA provisions for fire protection, including but not limited to those listed in OSHA 1910.151, 155, 156, 157, and 1910.1101, which apply to torch application. The contractor should be familiar with NFPA 58 "Standard for the Storage and Handling of Liquefied Petroleum Gas" and any other appropriate publications of the National LP Gas Association.

FIRE DEPT. REGULATIONS

The contractor should be familiar with all local fire codes in his area. The contractor is responsible for obtaining all necessary permits or certificates before work is started.

PERSONNEL

Proper clothing should be worn at all times while installing any modified membrane. Long sleeve shirt, long pants, leather or durable flat soled shoes and work gloves.

Workmen, other than the torch operator, should be no closer than 3' from open flame.

It is essential that the installer be well trained and fully understand the methods of application. Installation of this membrane should be performed only by a professional roofing contractor, well-trained in the methods described herein.

As with any roofing project, good roofing practices should always be followed. Consult the BITEC Specification and Details book for information governing certain systems.

SPECIFICATION:
Mineral Design. 1
NON-NAILABLE DECK

MDA (APP Modified) and
MDS (SBS Modified)

Apply this system using the appropriate BITEC approved base flashing, metal flashing or wall covering as specified in the most current edition of the BITEC "Roofing Material Specifications and Details" publication.

SEC. 1.00 INSULATION

The following insulations are acceptable for use with Mineral Design:

- PERLITE
- GLASS FIBER
- POLYISOCYANURATE
- WOOD FIBER
- CELLULAR GLASS

SEC. 2.00 CANTS

Flashing details, where the transition is from the horizontal to a vertical surface, a non-combustible cant strip must be used.

SEC. 3.00 BASE SHEET

A minimum of one ply of fiberglass TYPE G2 base sheet must be installed over the insulation or deck before the membrane is heat welded.

SEC. 4.00 FASTENERS

Consult Factory Mutual Research Publications governing your geographical region, or FM J.I.OQ3A3.AM governing BITEC products and systems.

SEC. 5.00 OUTLETS FOR APP MEMBRANES:

Drainage outlets shall be installed below the roof deck surface to permit POSITIVE DRAINAGE of the roof deck and to prevent water ponding at the drain rim. Base ply should be evenly trimmed with the drain flange, followed with a 40" x 40" heat welded collar of BITEC APS-4T. This collar must extend into and be fully adhered to the interior of the drain flange and interior surface. The Mineral Design membrane shall be fully adhered to the base ply, APS-4T flashing collar and extend into the drain. Clamp ring should be installed

and tightened while the membrane is hot. A 4 lb. Lead or 16 oz. copper flashing is optional between the collar and the Mineral Design field membrane. APS-4T collar should extend 4" beyond the lead or copper flashing.

SEC. 6.00 PIPE FLASHINGS FOR APP MEMBRANES;

Where penetrations occur in the roof surface a collar of APS-4T should be installed over the base ply, extending a minimum of 4" beyond the flanges. A metal flashing shall be installed having a continuous flange 4" minimum, on top of the APS-4T collar. (On nailable decks, the metal flange must be nailed 3" o.c., 3/4" from the perimeter.)

ALL METAL FLASHINGS MUST BE PRIMED WITH AN ASPHALT PRIMER AND ALLOWED TO DRY BEFORE MEMBRANE AND FLASHINGS ARE INSTALLED.

The Mineral Design field membrane must be fully adhered to the APS-4T collar and metal flange. All seams must be troweled and filled with molten modified bitumen.

SEC. 7.00 OUTLETS FOR SBS MEMBRANES:

Drainage outlets shall be installed below the roof deck surface to permit POSITIVE DRAINAGE of the roof deck and to prevent water ponding at the drain rim. Base ply should be evenly trimmed with the drain flange, followed with a 40" x 40" hot applied collar of BITEC SPS-3H. This collar must extend into and be fully adhered to the interior of the drain flange and interior surface. The BITEC Mineral Design membrane shall be fully adhered to the base ply, SPS-3H flashing collar and extend into the drain. Clamp ring should be installed and tightened while the membrane is hot. A 4 lb. lead or 16 oz. copper flashing is optional between the collar and the Mineral Design field membrane. The SPS-3H collar should extend 4" beyond the lead or copper flashing.

SEC. 8.00 PIPE FLASHINGS FOR SBS MEMBRANES;

Where penetrations occur in the roof surface, a collar of SPS-3H should be installed over the base ply extending a minimum of 4" beyond the flanges. A metal flashing shall be installed having a continuous flange 4" minimum, on

top of the SPS-3H collar. (On nailable decks, the metal flange must be nailed 3" o.c., 3/4" from the perimeter.)

ALL METAL FLASHINGS MUST BE PRIMED WITH AN ASPHALT PRIMER AND ALLOWED TO DRY BEFORE MEMBRANE AND FLASHINGS ARE INSTALLED.

The Mineral Design field membrane must be fully adhered to the SPS-3H collar and metal flange. All seams must be troweled and filled with molten modified bitumen or hot asphalt.

SEC. 9.00 ROOF DECK

The roof deck must be smooth, dry, clean and free of sharp projections and depressions, and properly graded to outlets.

THE ROOFING CONTRACTOR, ARCHITECT, AND ENGINEER MUST ALLOW FOR POSITIVE DRAINAGE WHEN DESIGNING THE ROOF DECK OR ROOF SYSTEM. BITEC DEFINES POSITIVE DRAINAGE AS: ROOF DECK BECOMES DEVOID OF WATER WITHIN 72 HOURS AFTER LIQUID PRECIPITATION HAS OCCURRED. BITEC WILL NOT BE RESPONSIBLE FOR MEMBRANE DAMAGE AS A RESULT OF INADEQUATE ROOF DECK DRAINAGE.

******* WARRANTIES *******

BITEC, INC.

offers two warranties:

(1) 10-YR. MATERIAL ONLY

(2) 10-YR. LIMITED "INSURED" ROOFING WARRANTY*

In order to obtain warranty (2), which covers labor and materials, an AUTHORIZED BITEC APPLICATOR must install the roofing system. Final inspection by a BITEC FIELD REPRESENTATIVE is necessary before issuance of warranty. Information regarding BITEC warranties may be obtained from: MANAGER OF TECHNICAL SERVICES by calling 800-535-8597.

*Extended warranty periods are available, 12, 15 and 20 years.

SPECIFICATION:
Mineral Design. 2
NAILABLE DECK

MDA (APP Modified) and
MDS (SBS Modified)

Apply this system using the appropriate BITEC approved base flashing, metal flashing or wall covering as specified in the most current edition of the BITEC "Roofing Material Specifications and Details" publication.

SEC. 1.00 INSULATION

The following insulations are acceptable for use with Mineral Design:

- PERLITE
- GLASS FIBER
- POLYISOCYANURATE
- WOOD FIBER
- CELLULAR GLASS

SEC. 2.00 CANTS

Flashing details, where the transition is from the horizontal to the vertical surface, a noncombustible cant strip must be used.

SEC. 3.00 BASE SHEET

A minimum of one ply of fiberglass TYPE G2 base sheet must be installed over the insulation or deck before the membrane is heat welded.

SEC 4.00 FASTENERS

Consult Factory Mutual Research Publications governing your geographical region, or F.M. J.I.OQ3A3. AM governing BITEC products and systems.

SEC. 5.00 OUTLETS FOR APP MEMBRANES:

Drainage outlets shall be installed below the roof deck surface to permit POSITIVE DRAINAGE of the roof deck and to prevent water ponding at rim. Base ply should be evenly trimmed with the drain flange, followed with a 40" x 40" heat welded collar of BITEC APS-4T. This collar must extend into and be fully adhered to the interior of the drain flange and interior surface. The Mineral Design membrane shall be fully adhered to the base ply,

APS-4T flashing collar and extend into the drain. Clamp ring shall be installed while the membrane is still hot. A 4 lb. lead or 16 oz. copper flashing is optional between the collar and the Mineral Design field membrane. APS-4T collar should extend 4" beyond the lead or copper flashing.

SEC. 6.00 PIPE FLASHINGS FOR APP MEMBRANES;

Where penetrations occur in the roof surface a collar of APS-4T should be installed over the base ply, extending a minimum 4" beyond the flanges. A metal flashing shall be installed having a continuous flange 4" minimum on top of the APS-4T collar. (On nailable decks, the metal flange must be nailed 3" o.c., 3/4" from the perimeter.)

ALL METAL FLASHINGS MUST BE PRIMED WITH AN ASPHALT PRIMER AND ALLOWED TO DRY BEFORE MEMBRANE AND FLASHINGS ARE INSTALLED.

The Mineral Design field membrane must be fully adhered to the APS-4T collar and metal flange. All seams must be troweled and filled with molten modified bitumen.

SEC. 7.00 OUTLETS FOR SBS MEMBRANES:

Drainage outlets shall be installed below the roof deck surface to permit POSITIVE DRAINAGE of the roof deck and to prevent water ponding at rim. Base ply should be evenly trimmed with the drain flange, followed with a 40" x 40" hot applied collar of BITEC SPS-3H. This collar must extend into and be fully adhered to the interior of the drain flange and interior surface. The BITEC Mineral Design membrane shall be fully adhered to the base ply, SPS-3H flashing collar and extend into the drain. Clamp ring shall be installed while the membrane is still hot. A 4 lb. lead or 16 oz. copper flashing is optional between the collar and the Mineral Design field membrane. The SPS-3H collar should extend 4" beyond the lead or copper flashing.

SEC. 8.00 PIPE FLASHINGS FOR SBS MEMBRANES;

Where penetrations occur in the roof surface, a collar of SPS-3H should be installed over the base ply extend-

ing a minimum 4" beyond the flanges. A metal flashing shall be installed having a continuous flange 4" minimum on top of the SPS-3H. (On nailable decks, the metal flange must be nailed 3" o.c., 3/4" from the perimeter.)

ALL METAL FLASHINGS MUST BE PRIMED WITH AN ASPHALT PRIMER AND ALLOWED TO DRY BEFORE MEMBRANE AND FLASHINGS ARE INSTALLED.

The Mineral Design field membrane must be fully adhered to the SPS-3H collar and metal flange. All seams must be troweled and filled with molten modified bitumen or hot asphalt.

SEC. 9.00 ROOF DECK

The roof deck must be smooth, dry, clean and free of sharp projections and depressions, and properly graded to outlets.

THE ROOFING CONTRACTOR, ARCHITECT AND ENGINEER MUST ALLOW FOR POSITIVE DRAINAGE WHEN DESIGNING THE ROOF DECK OR ROOF SYSTEM. BITEC DEFINES POSITIVE DRAINAGE AS: ROOF DECK BECOMES DEVOID OF WATER WITHIN 72 HOURS AFTER LIQUID PRECIPITATION HAS OCCURRED. BITEC WILL NOT BE RESPONSIBLE FOR MEMBRANE DAMAGE AS A RESULT OF INADEQUATE ROOF DECK DRAINAGE.

***** **WARRANTIES** *****

BITEC, INC.

offers two warranties:

- (1) 10-YR. MATERIAL ONLY
- (2) 10-YR. LIMITED "INSURED" ROOFING WARRANTY*

In order to obtain warranty (2), which covers labor and materials, an AUTHORIZED BITEC APPLICATOR must install the roofing system. Final inspection by a BITEC FIELD REPRESENTATIVE is necessary before issuance of warranty. Information regarding BITEC warranties may be obtained from: MANAGER OF TECHNICAL SERVICES by calling 800-535-8597.

*Extended warranty periods are available, 12, 15 and 20 years.

Planning

Each Mineral design pattern has a specific pattern repeat. To align the pattern and achieve maximum use of the roll, a certain portion of the repeat will not be used; so the installer should expect to have a certain percentage of waste on each project.

To help you approximate the material needed, the following table is given designating each pattern's repeat length. You may have to remove up to and including 50% of

this figure for alignment purposes, depending upon project requirements. Also, remember that you must provide a 6" minimum end-lap.

PATTERN	REPEAT
Circles & Squares	12.0"
Tiles	13.6"
Strip Slates	8.1"
Winding Fantasy	30.3"
Oval Slates	7.9"
Rhombus	12.0"
Bricks.....	3.5"
Camouflage.....	0.0"

When cutting the membrane, it is recommended that the applica-

tor use a straight-edge.

Proper side lap alignment is essential to successfully complete the pattern. A factory 3.5" side lap is provided with adjacent design to facilitate this.

BITEC, INC. has produced this product within design tolerances, and is not responsible for the improper and/or unsuccessful installation of this product.

CAUTION: It is the installer's responsibility to align patterns correctly. BITEC, INC. will not be responsible for incorrect installation of Mineral Design Products.

SPECIFICATIONS:	MDA (APP Modified)	MDS (SBS Modified)
ROLL SIZE	10 M ²	10 M ²
APPROVALS	UL (R13231)	UL (R13231)
SOFTENING POINT (ASTM D-36)	302°F (150°C)	250°F (120°C)
REINFORCEMENT	Spunbond Composite Reinf.	Spunbond Composite Reinf.
PENETRATION (ASTM D5)	40 dmm @ 25°C	40 dmm @ 25°C
SLIDE (UNI-8202)	<1 mm	<1 mm
COLD FLEXIBILITY (UNI-8202)	passed +5°F (-15°C)	passed -23°F (-30.1°C)
WATER TIGHTNESS (CGSB 37-GP-56M)	passed	passed
DYNAMIC PUNCTURE (CGSB 37-GP-56M)	passed	passed
STATIC PUNCTURE (CGSB 37-GP-56M)	passed	passed
TENSILE STRENGTH (ASTM D-412)	MD = 100 lbf/in XMD = 100 lbf/in	MD = 105 lbf/in XMD = 105 lbf/in
ELONGATION (ASTM D412)	MD = 45% XMD = 45%	MD = 60% XMD = 60%
LOAD STRAIN PRODUCT (CGSB 37-GP-56M)	MD = 40,012 n XMD = 40,012 n	MD = 56,048 n XMD = 56,048 n
THICKNESS	4 mm	4 mm
ROLL WEIGHT, APPROX.	107 lbs	107 lbs
COVERAGE, INSTALLED APPROX.	97 ft ²	97 ft ²
TOTAL SURFACE AREA, APPROX.	107.6 ft ²	107.6 ft ²

All Information is given in good faith, but normal tolerances of manufacture and testing will apply. BITEC reserves the right to improve and change its products at any time without prior notice or advice. The use of BITEC products is determined by local conditions and individual

requirements of each contract. In consideration of the many factors involved, BITEC cannot be held responsible for the application of its products and for conditions beyond its control. All claims filed against BITEC warranties will be subject to the provisions set forth at the

date of warranty issuance, and any addendums thereto. Under no circumstances will BITEC be held liable for any damage, whether personal injury or property damage, which occur during or after the application of the membrane.

PARAPET WALL DETAIL

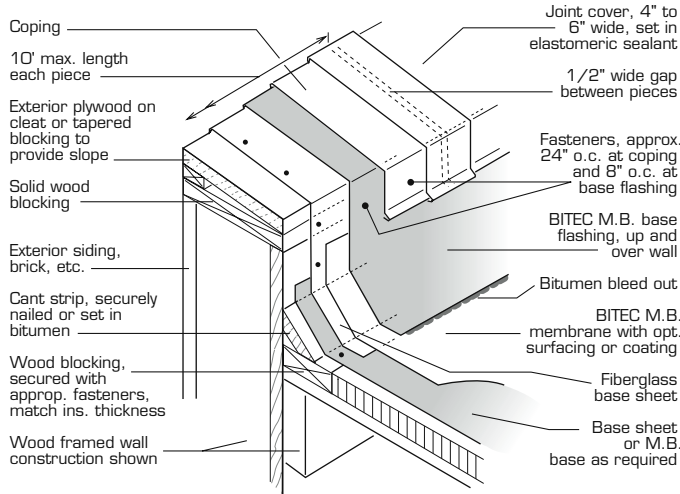

EDGE DETAIL

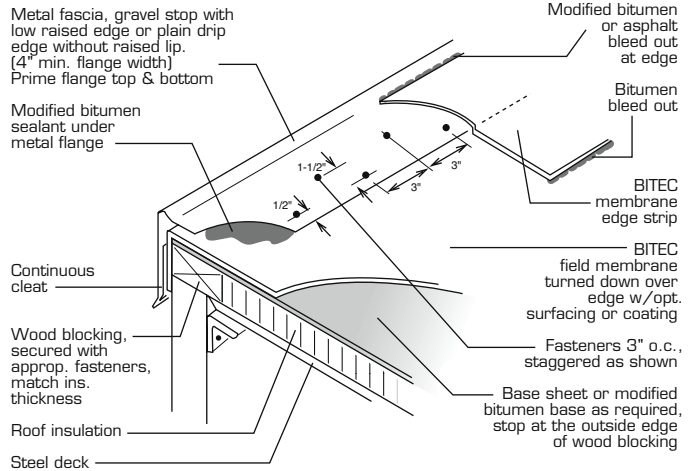

ROOF DRAIN DETAIL

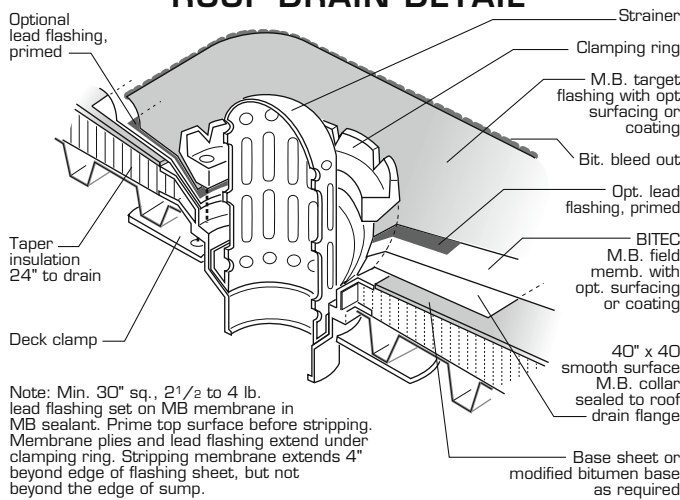

VENT PIPE DETAIL

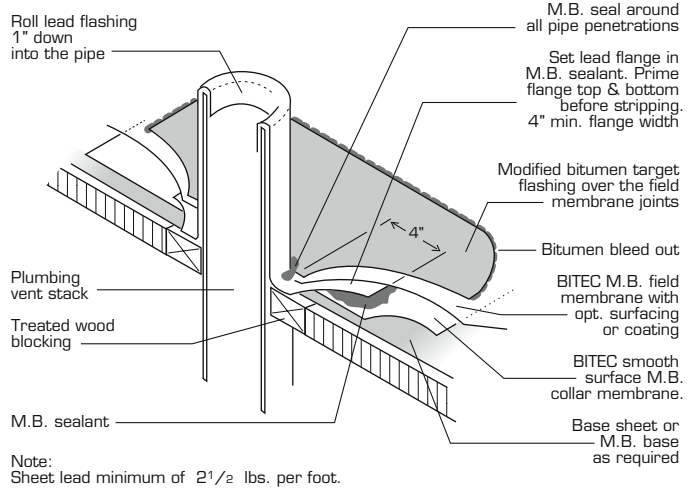

DISTRIBUTED BY:

APPROVALS:



Membrane for Roofing Systems
Classified By
Underwriters Laboratories, Inc.
As to an external fire exposure only
49S8

MEMBER OF:



BITEC

BITUMEN TECHNOLOGY™

MANUFACTURERS OF ADVANCED TECHNOLOGY WATERPROOFING MEMBRANES

P.O. Box 497 • No. 2 Industrial Park Drive • Morrilton, Arkansas 72110 • Fax (501) 354-3019 • Phone 1-800-535-8597

Visit our web site at www.bi-tec.com